



EPC-PM9080R

20 MPXL Multilens

Features

- Four 5MP 1/2.8" STARVIS CMOS image sensor
- 4 adjustable lenses in one camera, each lens up to 5 MP (2592 × 1944) @25/30 fps
- 2.7 to 13.5 mm motorized lens
- True WDR, 3D DNR, ROI, HLC, BLC, Defog
- Support face, human, vehicle detection and capture
- Intelligent analytics: intrusion, single line crossing, double line crossing, loitering, wrong-way, illegal parking, people counting, enter area, leave area and smart motion detection
- Built-in microphone, 1/1 audio in/out, 4/2 alarm in/out
- Built-in SD card slot, up to 1TB
- Smart IR distance up to 40 m
- IP67, IK10

Technical Specification

Image Sensor	4 × 1/2.8" Progressive Scan CMOS
Max. Resolution	5MP (2592 × 1944)
Electronic Shutter	Auto/Manual, 1/5 to 1/20,000s
Min. illumination	Color: 0.03 Lux @ (F1.6, AGC ON) , B/W: 0 Lux with light on
Day & Night	IR cut filter
Illumination Distance	IR distance up to 40m (131.2 ft)
Illumination On/Off Control	Auto/Manual
Illumination Type	IR
Lens Type	Motorized focus
Iris	DC- Iris
Focal Length	2.7 to 13.5 mm
F Number	F1.6
Angle of View	H: 95.6° to 26.9°, V: 65.4° to 20.5°

EPC-PM9080R

20 MPXL Multilens



Technical Specification

Angle Adjustment	Pan: -180° to 180°, Tilt: 0° to 130°, Rotation: 0° to 355°
Streaming Capability	3 Streams
Stream/Frame Rate	Stream1: 2592 × 1944, 2592 × 1520, 1920 × 1080, 1280 × 720 @ 25/30fps Stream2: D1, VGA, CIF @ 25/30fps Stream3: VGA, CIF, QVGA @25/30fps
Bit Rate Control	CBR/VBR
Bit Rate	Stream1: 500 kbps to 12 Mbps Stream2: 100 kbps to 6 Mbps Stream3: 100 kbps to 3 Mbps
Region of Interest	Support
Smart Encode	Support
Bit Rate	64Kbps (G.711), 128Kbps (RAW_PCM)
Image Adjustment	Brightness, Sharpness, Contrast, Saturation adjustable
Aisle Mode	Support
Mirror	Support
White Balance	Auto/Manual
Day/Night Setting	Auto, Day, Night, Time
Compression	G.711, RAW_PCM
Noise Reduction	2D/3D DNR
Image Enhancement	HLC, BLC, Defog
Wide Dynamic Range	True WDR
S/N Ratio	55dB

EPC-PM9080R

20 MPXL Multilens

Technical Specification

Privacy Masking	Supports 1 to 4 channels
Multi-Object Detection	Supports face, human, vehicle detection and capture.
Intelligent Analytics	Intrusion, Single line crossing, Double line crossing, Loitering, Wrong-way, Illegal parking and Smart motion detection. Support alarm triggering by specified target types (human and vehicle)
People Counting	Supports
Basic Events	Disk alarm, Network alarm, I/O alarm, Motion detection alarm, Abnormal sound detection
Protocols	IPv4/IPv6, RTSP/ RTCP/RTP, TCP/UDP, HTTPS, DHCP, DNS, DDNS, PPPoE, UPnP, ICMP IGMP, FTP, NTP, SMTP, 802.1x, SNMP
Interoperability	ONVIF (profile S/T/G/M), SDK, CGI
Streaming Method	Multicast
Max. User Access	10 Users
Web Viewer	<IE11, Chrome, Firefox
Language	English, Chinese, Polish, Italian, Portuguese, Spanish, Russian, French, Czech, Hungarian. Default: English
Network Interface	1 Ethernet (10/100 Base-T) RJ-45 Connector
Built-in Microphone	Support
Audio Interface	1ch Input, 1ch Output
Alarm Interface	4 ch Input, 2 ch Output
Reset Button	Support
RS-485	Support
CVBS Interface	Support
SD Card Slot	Built-in, up to 1 TB
Power Supply	DC12V (-15% to +25%)/PoE (IEEE 802.3at)
Power Consumption	Max 20 W

EPC-PM9080R

20 MPXL Multilens

Technical Specification

Operating Temperature	-40°C to 60°C (-40°F to 140°F)
Operating Humidity	Less than 90% RH
Ingress Protection	IP66, IK10
Certifications	CE/FCC
Casing	Metal + Plastic
Net Weight	4 kg (8.82 lb) (Bracket not included)
Dimensions	282 mm (L) × 206.3mm (H) (Bracket not included)

Dimension

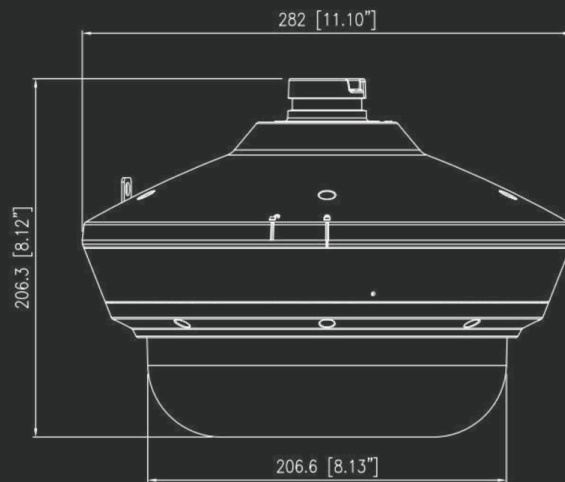

EPC-PM9080R

20 MPXL Multilens

Accessories - Included



EP-CBK506B - Wall Bracket

Accessories - Optional



EP-BK604B - Pole Mount



EP-BK359 - Pole Mount



EP-BK367 - Junction Box



EP-BK605 - Corner Mount



EP-BK358 - Corner Mount



EP-BK348A - Ceiling Bracket

Ordering Information

EPC-PM9080R	Entrypass 20 MPXL Multilens
EP-CBK506B	Wall Bracket
EP-BK604B	Pole Mount
EP-BK359	Pole Mount
EP-BK367	Junction Box
EP-BK605	Corner Mount
EP-BK348A	Ceiling Bracket



www.entypass.net

Malaysia

No. 40, Jalan TPP 1/10, Taman Industri Puchong,
Batu 12 Jalan Puchong, 47160 Puchong
Selangor Darul Ehsan, Malaysia.
Tel : +603 8068 1929
Fax : +603 8062 6937
Email : info@entypass.net

Singapore

No. 1, UBI View, #03-03, Focus ONE Building,
Singapore 408555.
Tel : +65- 6841 7242
Fax : +65- 6841 3937
Email : info@entypass.net

Indonesia

PT Brikom Entripas Indonesia
Jl. Griya Utama, Komplek Puri Mutiara Blok BF No. 17,
RT.1/RW.20, Sunter Agung, Tj. Priok, Kota Jkt Utara,
Daerah Khusus Ibukota Jakarta 14350.
Tel : +62 21 2937 6098
Email : info@entypass.net